

## Type WB-240 Wheelie Bin Tipper

The type WB-240 Wheelie Bin Tipper has been designed for emptying standard 240 litre plastic bins. The Bin is secured in the cradle by a Safety Chain allowing the bin to be lifted/transported about the workplace and emptied. The tipping operation is simple and safe with the operator never having to leave his seat using a draw chord to activate the tipping action.

Standard finish on all Wheelie Bin Tippers is painted enamel.

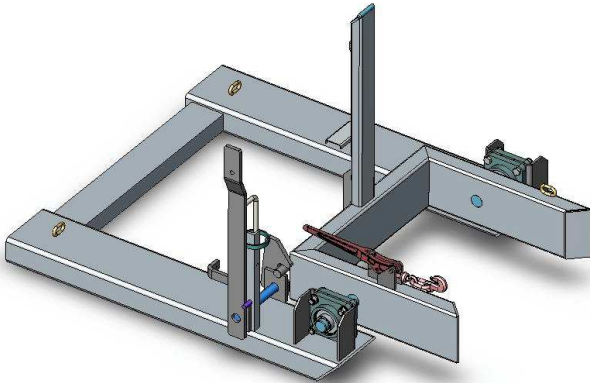

### SPECIFICATIONS:

- Safe Working Load (SWL) 500kg
- Load Centre 1000mm
- Unit Weight 100kg
- Pocket Size 165 x 65
- Pocket Centres 815mm
- Capable of 180° Rotation
- Horizontal C of G 700mm
- Vertical C of G 100mm

