

Type TSC2 Trolley Spill Bin

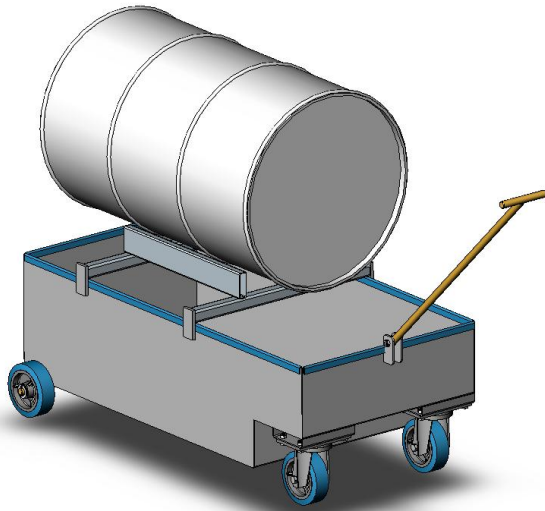

The type TSC2 Trolley Spill Bin is designed for rack mounting a single Drum. The Bin is mounted on Ø150 wheels and comes complete with handle for quick and easy transport making it ideal for manoeuvring and dispensing liquid without spillage. To empty the containment area, a single Drain Plug has been provided at the rear of the Spill Bin. All type TSC Spill Bins come in a long life Zinc plated finish.

All models have a spill capacity of at least 110% of the largest package in accordance with Australian Standards, being classified as “portable” units.

For all other specifications refer to the diagram & chart below.

