

## Type TJS5 Tilt Jib (Short)

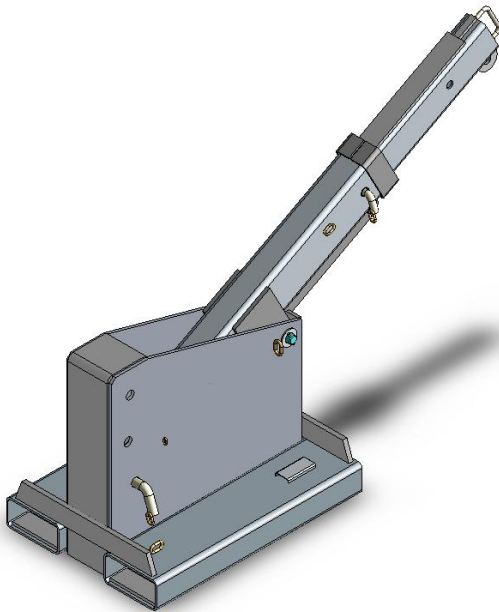

The type TJS5 Tilt Jib (Short) is designed with a tilt facility allowing extra height to compensate for the hook and sling length lost when lifting with a Jib attachment. A maximum height of 1.36 metres can be gained while the Jib can be fully extended to 2.03 metres. This slip-on attachment is held to the Forklift by a safety chain. The Jibs overall length when closed is 1.36 metres.

The standard finish on the type TJS5 Tilt Jib (Short) is Zinc Plated.

### SPECIFICATIONS:

- Safe Working Load (SWL) 4750kg Max.
- Unit Weight 180kg
- Load Centre 920mm
- Pocket Size 185 x 75
- Pocket Centres 370 mm
- Horizontal C of G 650mm
- Vertical C of G 300mm

