

## Type TJCL45 Tilt Jib (Long)

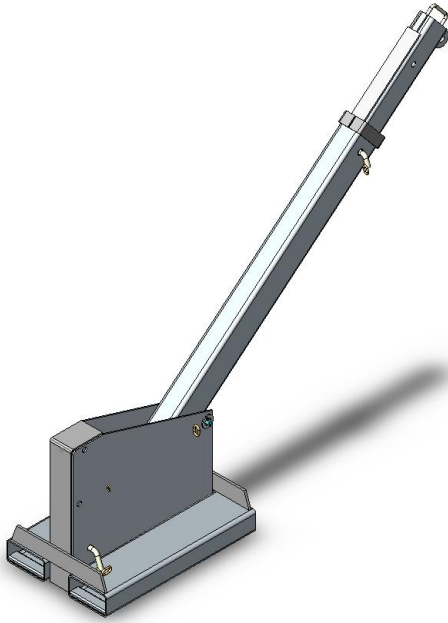

The type TJCL45 Tilt Jib (Long) is one of our most versatile Forklift Jib attachments in our range, allowing extra height to 2.23 metres, with a 3.53 metre reach when fully extended. This slip-on attachment is held to the Forklift by a safety chain. The Jibs overall length when closed is 2.1 metres.

The standard finish on the type TJCL45 Tilt Jib (Long) is Zinc Plated.

### SPECIFICATIONS:

- Safe Working Load (SWL) 4500kg Max.
- Unit Weight 190kg
- Load Centre 770mm
- Pocket Size 185 x 68mm
- Pocket Centres 322 mm
- Horizontal C of G 1080mm
- Vertical C of G 345mm

