

Type STJS2.5 Tilt Jib (Short)

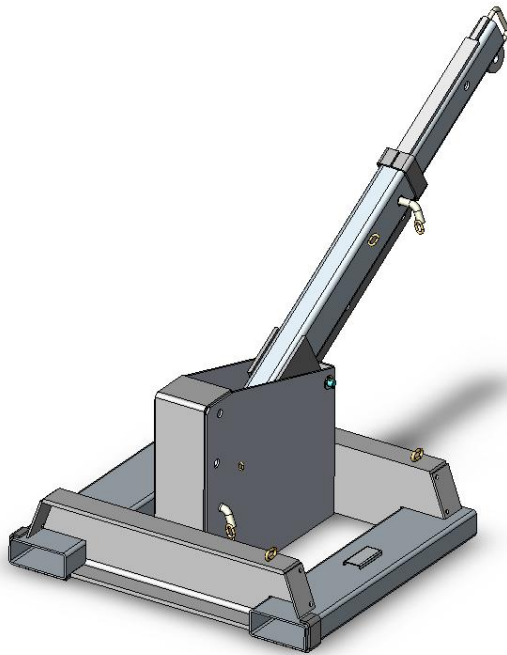

The type STJS2.5 Tilt Jib (Short) is designed with a tilt facility allowing extra height to compensate for the hook and sling length lost when lifting with a Jib attachment. A maximum height of 1.4 metres can be gained while the Jib can be fully extended to 2.1 metres. This Jib has been designed with wide pockets suitable for Forklifts with special hydraulic Tine Positioners. This slip-on attachment is held to the Forklift by a safety chain. The Jibs overall length when closed is 1.43 metres.

Supplied with safety swivel Hook and Shackle.

SPECIFICATIONS:

- Safe Working Load (SWL) 2500kg Max.
- Unit Weight 160kg
- Load Centre 905mm
- Pocket Size 165 x 65
- Pocket Centres 740 mm
- Horizontal C of G 650mm
- Vertical C of G 300mm
- Zinc Finish

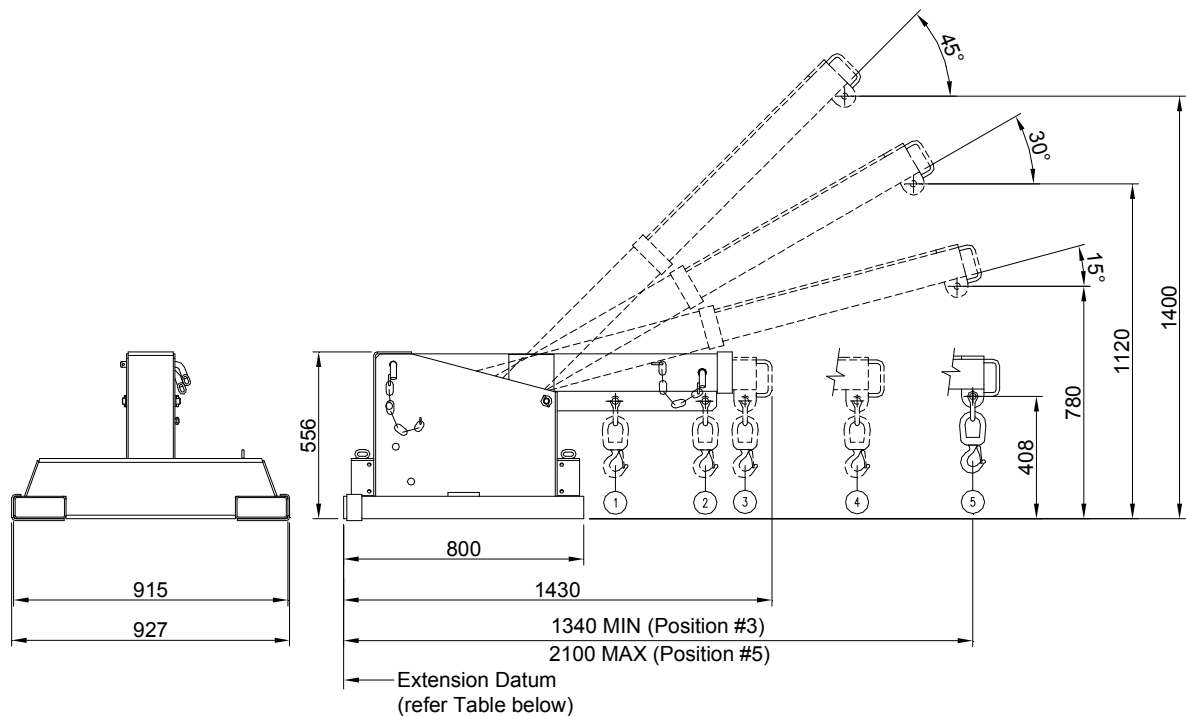

SAFE WORKING LOADS (SWL) PER POSITION

POSITION	1	2	3	4	5
EXTENSION (mm)	905	1205	1340	1720	2100
SWL (kg)	2500	1800	1200	900	750