

## Type SL-IBC/CDL Fully Enclosed Spill Bin

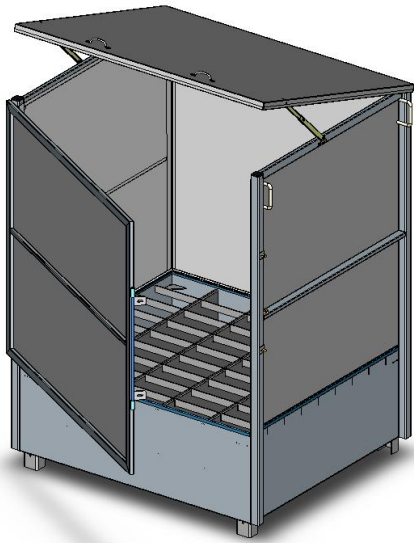

Similar to the type SL4/CDL Spill Bin the type SL-IBC/CDL Fully Enclosed Spill Bin has been specifically designed to suit the 1000 litre Intermediate Bulk Container (IBC) offering a complete protection against damaging and costly chemical spills with the added advantage of being fully enclosed. The 180 degree swinging front door is lockable for added security. Air vents may be added to the sides as an option. The baffled containment area allows the Spill Bin to be safely moved when full, minimising spillage. The unit has a Safe Working Load of 2000kg. To empty the containment area, a single Drain Plug has been provided at the front of the Spill Bin. All type SL Spill Bins come in a long life Zinc plated finish.

The type SL-IBC/CDL Spill Bin has a spill capacity of 1100 litres (110% of the IBC holding capacity) in accordance with Australian Standards, being classified as a "portable" unit.

For all other specifications refer to the diagram & chart below.

