

Type SFJS10 Fixed Jib (Short)

The type SFJS10 Fixed Jib (Short) is designed as an affordable general purpose Jib able to manoeuvre in confined spaces, with a 2.0 metre reach when fully extended. This Jib has been designed with wide pockets suitable for Forklifts with special hydraulic Tine Positioners. This slip-on Forklift attachment is held to the Forklift by a safety chain. The Jibs overall length when closed is 1.39 metres.

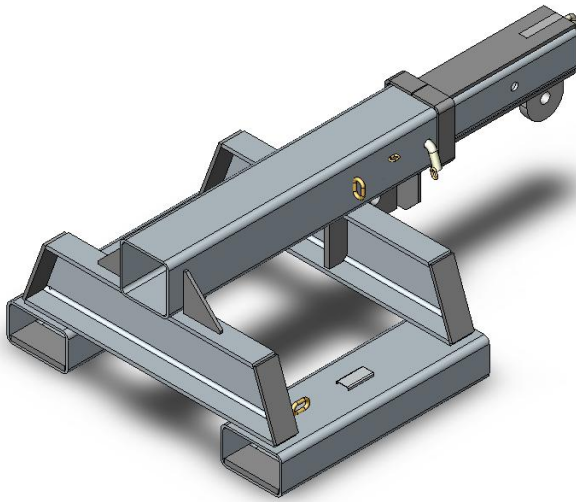

Supplied with safety swivel Hook and Shackle.

SPECIFICATIONS:

- Safe Working Load (SWL) 10,000kg Max.
- Unit Weight 400kg
- Load Centre 930mm
- Pocket Size 230 x 110
- Pocket Centres 875 mm
- Horizontal C of G 740mm
- Vertical C of G 100mm
- Zinc Finish

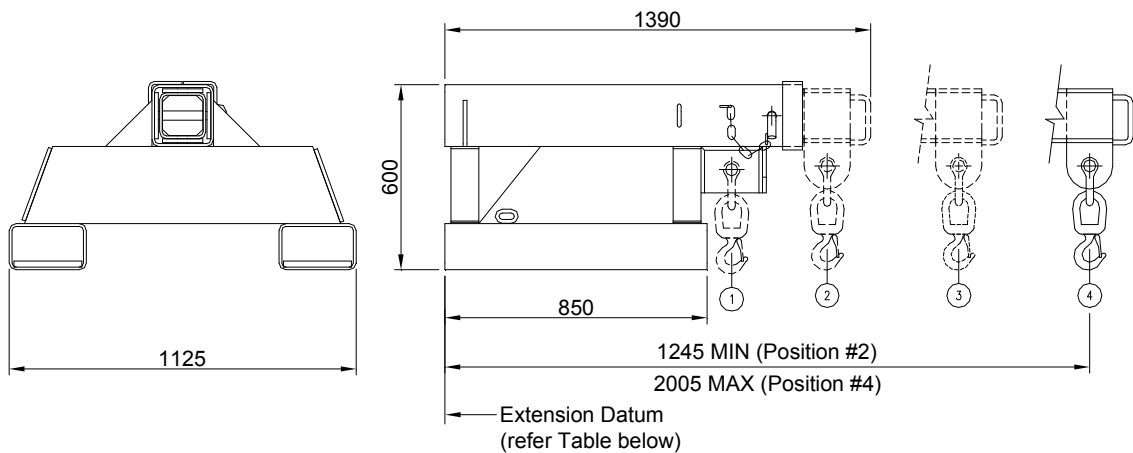

SAFE WORKING LOADS (SWL) PER POSITION

POSITION	1	2	3	4
EXTENSION (mm)	930	1245	1625	2005
SWL (kg)	10,000	4800	3600	3000