

## Type SDL1-WP Wide Pocket Drum Lifter

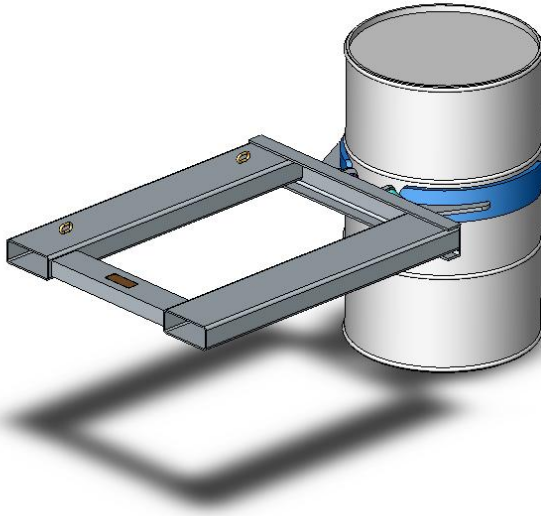

(The standard SDL1-WP Drum Lifter shown on this Product Specification sheet)

Designed for standard 205 litre steel drums, the fully automatic clamping action enables safe and precise placement of drums without the operator having to leave the Drivers seat. The drum is gripped by pushing the arms against the drum centre and driving forward with the Forklift. The arms will engage around the drum and lock under the rolling hoop when raised. The heavier the load, the tighter the grip becomes. To release the drum, simply lower the drum onto ground level and reverse the Forklift.

The type SDL1-WP Drum Lifter may be manufactured with pocket centres to suit your application. The finish on the Drum Lifter is either painted enamel on primed steel or H.D. Galvanised.

### SPECIFICATIONS (for standard 'WP' model):

- Pocket Size 165 x 65mm
- Pocket Centres 650mm
- Safe Working Load (SWL) 500kg
- Unit Weight 70kg
- Load Centre 1340mm
- HCG 720mm
- VCG 35mm

