

Type RS-IBC Spill Bin

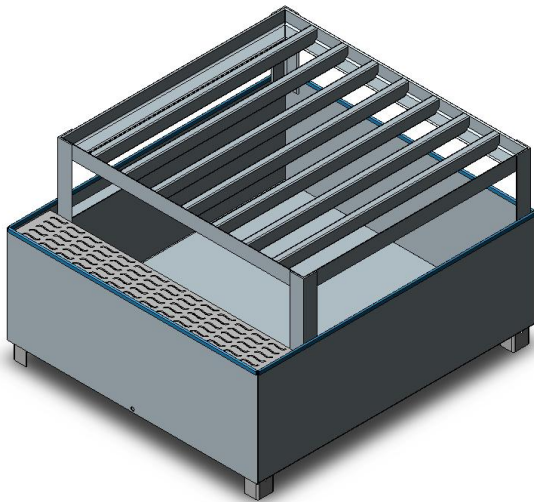

The type RS-IBC Spill Bins have been specifically designed for IBC's (Intermediate Bulk Containers) and are available in 2 different sizes to suit most IBC's on the market. This unit comes with a support Rack and Tray providing extra pouring height and comes in a long life Zinc plated finish, offering a complete protection against damaging and costly chemical spills. To empty the containment area, a single Drain Plug has been provided at the front of the Bin. The Safe Working Load of all units is 2000kg.

All type RS-IBC Spill Bins have a spill capacity (refer table below) of at least 110% of the IBC holding capacity in accordance with Australian Standards, being classified as "portable" units.

For all other specifications refer to the diagram & table below.

