

## Type RS2-2L Dual Drum Rack Storage Unit

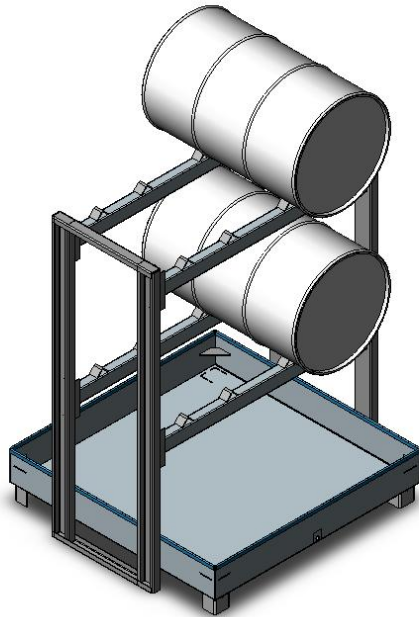

The type RS2-2L Dual Drum Rack Storage unit has been designed to rack up to two drums on each of two racks 740 & 1540mm above floor level. The Drum Rack Storage unit comprises of a stand alone drum rack and a spill containment tray to provide a safer working area by protecting against chemical spills. In the advent of a spill, the tray may be removed without disturbing the rack, and emptied by removing the drain plug provided.

The Unit Weight of the type RS2-2L Dual Drum Rack Storage unit (including the tray - type SP4 Spill Bin) is 110kg. All Drum Racking systems come in a long life Zinc plated finish.

Roller Support Angles may be fitted as an option. For all other specifications refer to the diagram below.

East West Engineering also has a range of Forklift Attachments to safely grab, rotate and/or turn drums for placement in all our Storage Systems.

### Tray Spill Capacity:

The spill capacity of the tray is at least 110% of the largest package in accordance with Australian Standards, being classified as a portable unit.

