

## Type ROB Roll Over Bin

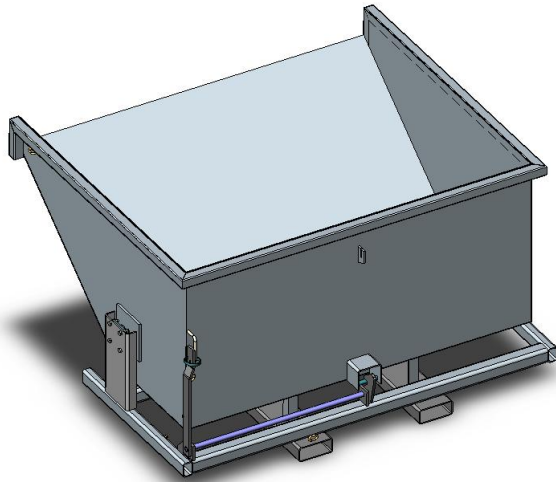

(Type ROB18 standard model shown)  
Refer 'ROB\_WL\_Sales' Product Specification sheet  
for Wheels & Crane Lug options.

The type ROB Roll Over Bin has been designed for a smooth tipping action with minimal impact during emptying. Side bearings prevent the bin being dislodged during tipping as is common with the roll over style bins. The cut away front design makes this bin ideal for tipping liquids. The release mechanism is activated by the Forklift operator pulling the pull chord from the driver's seat.

All type ROB bins have a Safe Working Load of 1000kg and range in sizes from 0.9 – 1.7 cubic metre capacities. These bins are available in either enamel painted over primed steel or H.D. Galvanised finish.

### SPECIFICATIONS:

- Pocket size 165 x 65mm
- Pocket Centres – 625mm
- Safe Working Load 1000kg
- Unit Weight – refer Table
- Volume Capacity – refer Table
- HCG 640mm
- VCG 465mm
- Wheels, Crane Lugs & Lid Optional
- Drain Valve & Strainer Optional

