

## Type PHD2200 Adjustable Pallet Hook

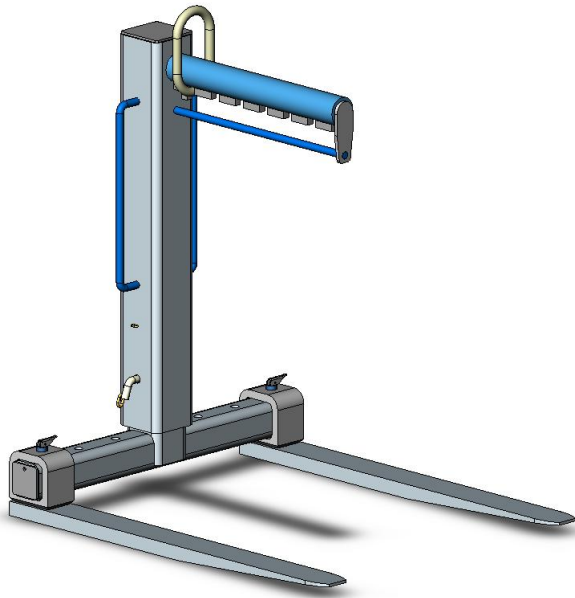

The type PHD2200 Adjustable Pallet Hook has been designed to handle palletted goods safely when being lifted by overhead crane. The unit features variable body height and adjustable Fork Tine widths making this crane attachment ideal for the transport and construction industry. The robust high tensile steel lightweight construction delivers maximum strength with zero maintenance and ease of use. Load balancing is via the moveable lifting ring with 6 positions available for balancing the load. The standard finish on the Pallet Hook is Zinc Plated.

The Pallet Hook has been designed & certified in accordance with Australian Standard AS 1418.1.

### SPECIFICATIONS:

- Safe Working Load (SWL) 2200kg
- Load Centre 600mm
- Unit Weight 215kg

