

## Type NSD Self Dumping Bin (Wheels & Crane Lug Options)

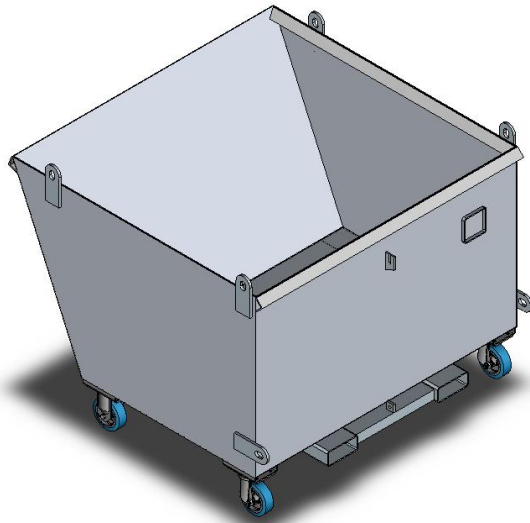

The type NSD Self Dumping Bin has been designed to provide an economical solution to collecting and disposing of industrial waste. Collection can be carried out at the point of manufacture. When transporting the bin to the discharge point, the Forklift tines are positioned fully under the bin utilising the Forklifts maximum lift capacity. To tip the bin, the Operator catches the bin on the edge of the bulk container and reverses the Forklift. When the tines clear the pivot point, raising the bin will permit a complete discharge of contents.

All type NSD bins have reinforced edging, a Safe Working Load of 1000kg and range in sizes from 0.7 – 2.0 cubic metre capacities. These bins are available in either enamel painted over primed steel or H.D. Galvanised finish.

### SPECIFICATIONS:

- Pocket size 165 x 65mm
- Pocket Centres – 635mm (NSD6 – 381mm)
- Safe Working Load 1000kg
- Unit Weight – refer Table
- Volume Capacity – refer Table
- HCG 750mm
- VCG 400mm
- Wheels, Crane Lugs & Lid Optional
- Drain Valve & Strainer Optional

(Type NSD15 with optional Wheels & Crane Lugs shown)  
Refer 'NSD\_Sales' Product Specification sheet  
for the standard model configuration.

