

## Type JTU Heavy Duty Tip-Up Bin (Wheels & Crane Lug Options)

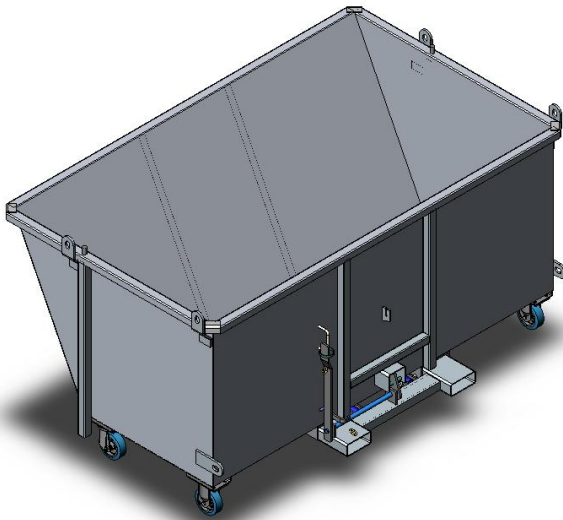

(Type JTU24 with optional Wheels & Crane Lugs shown)  
Refer 'JTU\_Sales' Product Specification sheet  
for the standard model configuration.

The type JTU Heavy Duty Tip-Up Bin has been manufactured from 3mm plate with welded strengthening ribs and has been designed with large capacity for bulk waste. The bin, having a forward Centre of Gravity, tips automatically when the release mechanism is activated by the Forklift operator pulling the pull chord from the driver's seat. Powerful shock absorbers prevent impact forces being transmitted to the Forklift mast during emptying. After emptying, lower the bin to ground level and reverse away to automatically close and lock bin in its horizontal position.

The type JTU Heavy Duty Tip-Up Bins are available in either enamel painted over primed steel or H.D. Galvanised finish.

### SPECIFICATIONS:

- Pocket size 165 x 65mm
- Pocket Centres – 735mm
- Safe Working Load 1000kg
- Unit Weight – refer Table
- Volume Capacity – refer Table
- HCG 800mm
- VCG 500mm
- Wheels, Crane Lugs & Lid Optional
- Plastic Lid Optional (for JTU-18 only)
- Drain Valve & Strainer Optional
- Hydraulic Option available

