

## Type GCN-2 Gas Cylinder Crane Cage

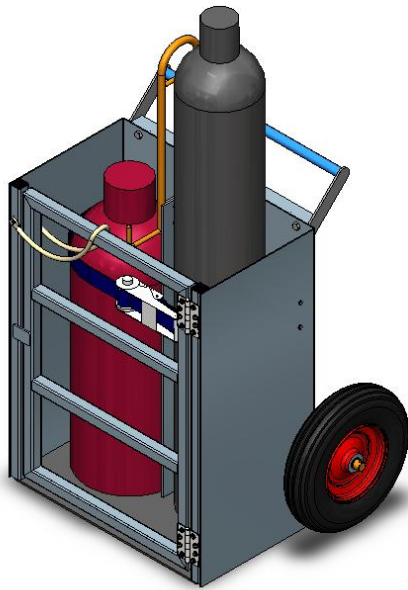

(Gas Cylinders not included)

The type GCN-2 Gas Cylinder Crane Cage has been designed to suit one type "G" Oxygen and one type "G" Acetylene gas cylinder. Provision has been made to store all hoses inside the cage. The cage is supplied with an internal loadbinder to securely fasten both cylinders. Fitted with Handle and  $\text{Ø}400\text{mm}$  air inflated rubber wheels, this cage can be transported manually or by Crane.

### SPECIFICATIONS:

- Single point lift
- Safe Working Load (SWL) 250kg
- Unit Weight 80kg
- Painted Enamel Chassis/Rims
- All other components – Zinc Plated

