

Type FJS2.5 Fixed Jib (Short)

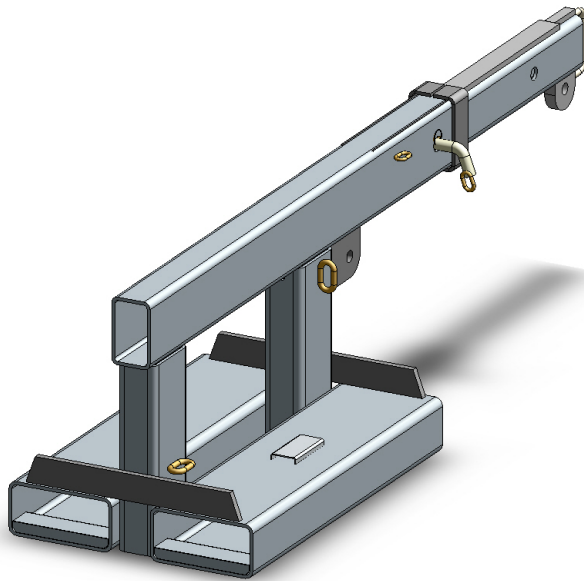

The type FJS2.5 Fixed Jib (Short) is designed as an affordable general purpose Jib able to manoeuvre in confined spaces, with a 1.96 metre reach when fully extended. This slip-on Forklift attachment is held to the Forklift by a safety chain. The Jibs overall length when closed is 1.3 metres.

The standard finish on the type FJS2.5 Fixed Jib (Short) is Zinc Plated.

SPECIFICATIONS:

- Safe Working Load (SWL) 2500kg Max.
- Unit Weight 100kg
- Load Centre 790mm
- Pocket Size 185 x 65
- Pocket Centres 275 mm
- Horizontal C of G 630mm
- Vertical C of G 135mm

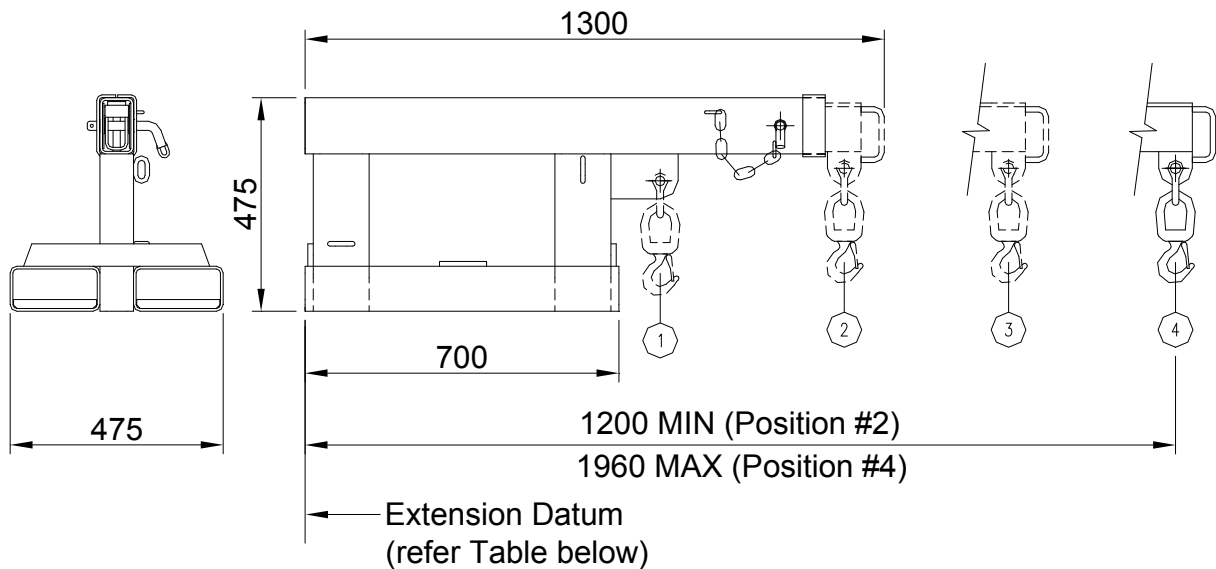

SAFE WORKING LOADS (SWL) PER POSITION

POSITION	1	2	3	4
EXTENSION (mm)	790	1200	1580	1960
SWL (kg)	2500	1200	900	750