

Type FJL5 Fixed Jib (Long)

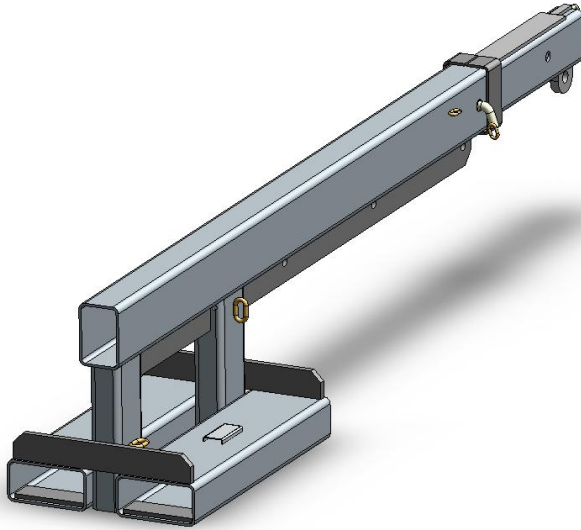

The type FJL5 Fixed Jib (Long) is designed as an affordable general purpose Jib with a 3.5 metre reach when fully extended. This slip-on Forklift attachment is held to the Forklift by a safety chain. The Jibs overall length when closed is 2.1 metres.

The standard finish on the type FJL5 Fixed Jib (Long) is Zinc Plated.

SPECIFICATIONS:

- Safe Working Load (SWL) 4750kg Max.
- Unit Weight 170kg
- Load Centre 935mm
- Pocket Size 185 x 75
- Pocket Centres 275 mm
- Horizontal C of G 1210mm
- Vertical C of G 200mm

