

Type FJCL45 Fixed Jib (Long)

The type FJCL45 Fixed Jib (Long) is designed as an affordable general purpose Jib with a 3.465 metre reach when fully extended. This slip-on Forklift attachment is held to the Forklift by a safety chain. The Jibs overall length when closed is 2.035 metres.

The standard finish on the type FJCL45 Fixed Jib (Long) is Zinc Plated.

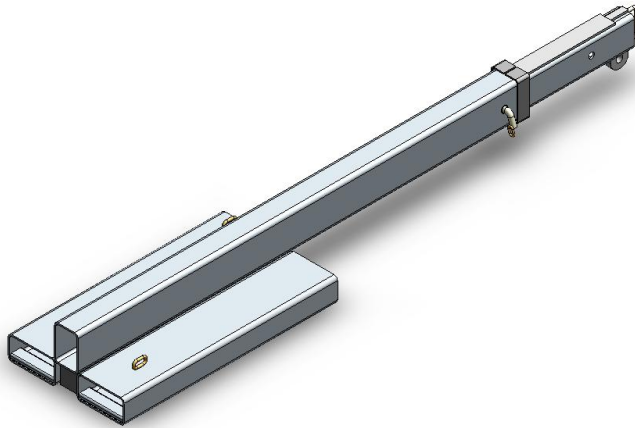

SPECIFICATIONS:

- Safe Working Load (SWL) 4500kg Max.
- Unit Weight 140kg
- Load Centre 870mm
- Pocket Size 185 x 65
- Pocket Centres 290 mm
- Horizontal C of G 1295mm
- Vertical C of G 125mm

