

Type DRW-NH Drum Rotator

The type DRW-NH Drum Rotator is designed to lift and rotate 205 litre Drums through 360° and is ideal for long reach applications. Handle rotation via a Gearbox of the drum cradle ensures minimum effort for fully controlled tipping, allowing complete emptying of the drum contents. A Chain Belly Strap with an eccentric lock holds the Drum firmly in position.

This slip-on attachment requires only the connection of a safety chain to a narrow carriage Forklift. The standard finish of this unit is Hot Dip galvanised.

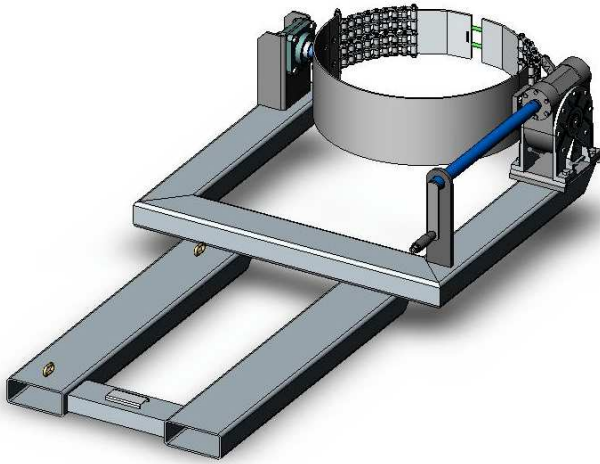

SPECIFICATIONS:

- Safe Working Load (SWL) 500kg
- Unit Weight 130kg
- 360° Rotation
- Load Centre 1640mm
- Pocket Size 165 x 65
- Pocket Centres 485mm
- Horizontal C of G 1100mm

