

Type DRW-NC Drum Rotator

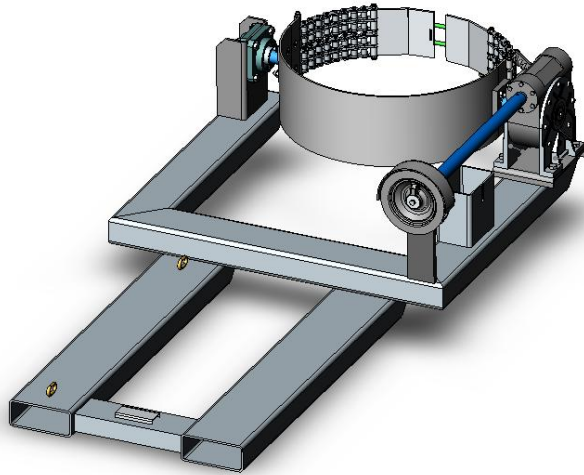

The type DRW-NC Drum Rotator is designed to lift and rotate 205 litre Drums through 360° and is ideal for long reach applications. A Hand Chain is used to rotate the Drum via a Gearbox for controlled rotation. A Chain Belly Strap with an eccentric lock holds the Drum firmly in position.

This slip-on attachment requires only the connection of a safety chain to a narrow carriage Forklift. The standard finish of this unit is Hot Dip galvanised.

SPECIFICATIONS:

- Safe Working Load (SWL) 500kg
- Unit Weight 140kg
- 360° Rotation
- Load Centre 1640mm
- Pocket Size 165 x 65
- Pocket Centres 485mm
- Horizontal C of G 1100mm

