

## Type DR-NC Drum Rotator

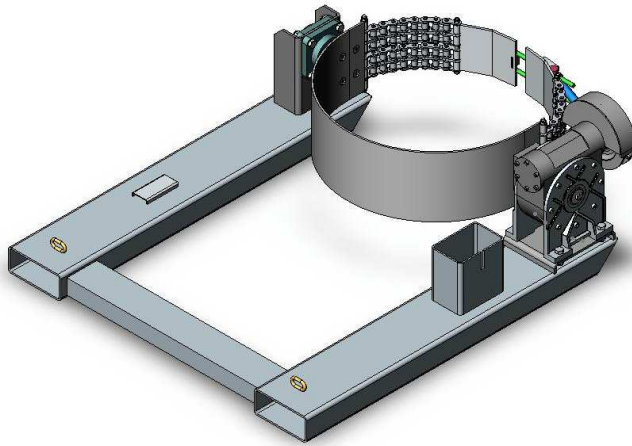

The type DR-NC Drum Rotator is designed to lift and rotate 205 litre Drums through 360° above the chest height of the Operator. A Hand Chain is used to rotate the Drum via a Gearbox for controlled rotation. A Chain Belly Strap with an eccentric lock holds the Drum firmly in position.

This slip-on attachment requires only the connection of a safety chain to the Forklift. The standard finish of this unit is Hot Dip galvanised.

### SPECIFICATIONS:

- Safe Working Load (SWL) 500kg
- Unit Weight 100kg
- 360° Rotation
- Load Centre 930mm
- Pocket Size 165 x 65
- Pocket Centres 820mm
- Horizontal C of G 750mm

