

Type DR-NC Drum Rotator with PBO Option

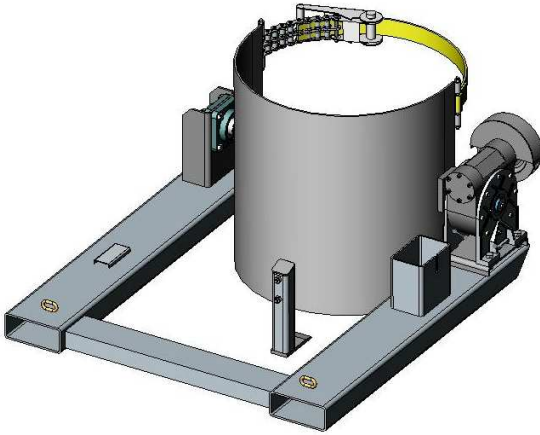

The type DR-NC Drum Rotator with the PBO Cradle fitted is designed to lift and rotate plastic Drums and Barrels as well as 205 litre steel Drums through 360° above the chest height of the Operator. A Hand Chain is used to rotate the Drum/Barrel via a Gearbox for controlled rotation. The dual Woven/Chain combination Belly Straps holds the Drum/Barrel firmly in position.

This slip-on attachment requires only the connection of a safety chain to the Forklift. The standard finish of this unit is Hot Dip galvanised.

SPECIFICATIONS:

- Safe Working Load (SWL) 350kg
- Unit Weight 130kg
- 360° Rotation
- Load Centre 940mm
- Pocket Size 165 x 65
- Pocket Centres 820mm
- Horizontal C of G 800mm

