

Type DL1000PBO Drum Lifter

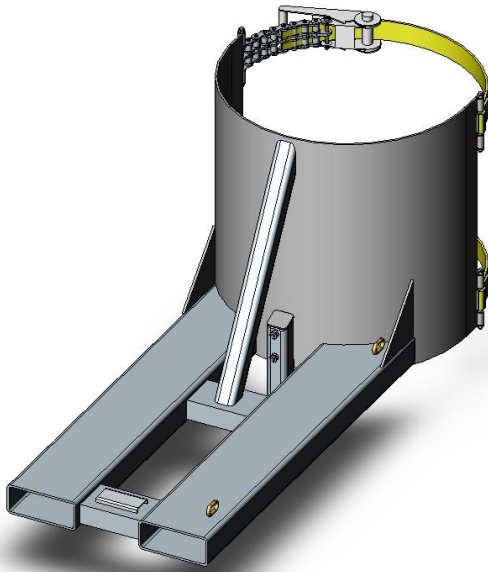

The type DL1000PBO Drum Lifter would be considered the safest Drum Lifter available. This unit uses dual woven/chain combination belly straps with ratchet tightening to allow clamping of varying diameter drums, including standard plastic drums as well as barrels. With the added feature of a Bin Support Leg, drums/barrels may be moved with 100% security.

SPECIFICATIONS:

- Safe Working Load (SWL) 350kg
- Load Centre 1160mm nominal
- Unit Weight 75kg
- Pocket Size 165 x 65mm
- Pocket Centres 335mm
- HCG 750mm
- VCG 90mm

