

Type DC-R2 Hydraulic Drum Rotator

The type DC-R2 Hydraulic Drum Rotator is designed to lift and rotate 205 litre Drums. A Chain Belly Strap with an eccentric lock holds the Drum firmly in position. Rotation is provided by the Forklift hydraulics and controlled by the 3rd function lever.

This unit is designed with a heavy lift capacity. The standard finish is painted enamel.

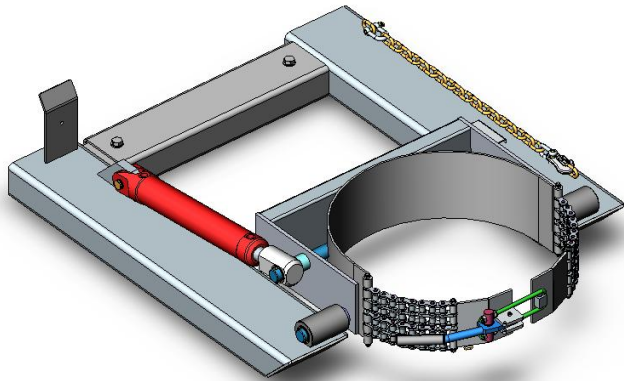

SPECIFICATIONS:

- Safe Working Load (SWL) 1000kg
- Unit Weight 135kg
- 130° Rotation
- Load Centre 1050mm
- Pocket Size 185 x 65
- Pocket Centres 874mm
- Horizontal C of G 600mm

