

## Type DC-GR2 Hydraulic Drum Rotator

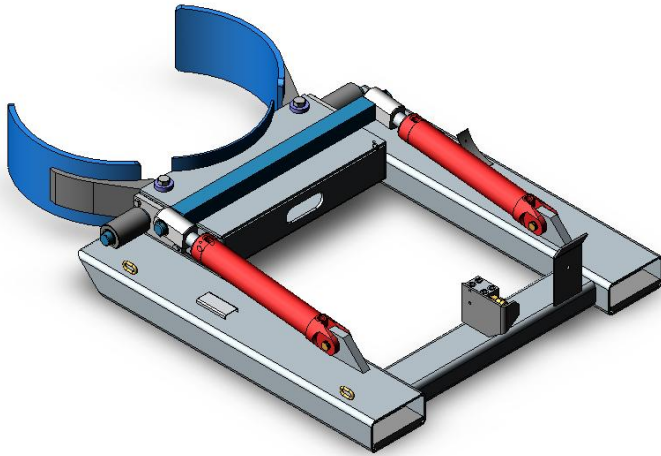

The type DC-GR2 Hydraulic Drum Rotator is a heavy duty 205 litre Drum Lifter with hydraulic grab/rotation ability. With 1 tonne lift capacity, this attachment is ideal for the recycle industry and for mining applications. This lifter is able to pick a single drum from a pallet of 4 without disturbing the other 3 drums.

This unit is fitted with quick connect couplings for connection to the 3<sup>rd</sup> and 4<sup>th</sup> Forklift hydraulic valves. The standard finish is painted enamel.

### SPECIFICATIONS:

- Safe Working Load (SWL) 1000kg
- Unit Weight 175kg
- 130° Rotation
- Load Centre 1307.5mm
- Pocket Size 185 x 65
- Pocket Centres 874mm
- Horizontal C of G 700mm

