

## Type DB Drop Bottom Bin c/w Wheels

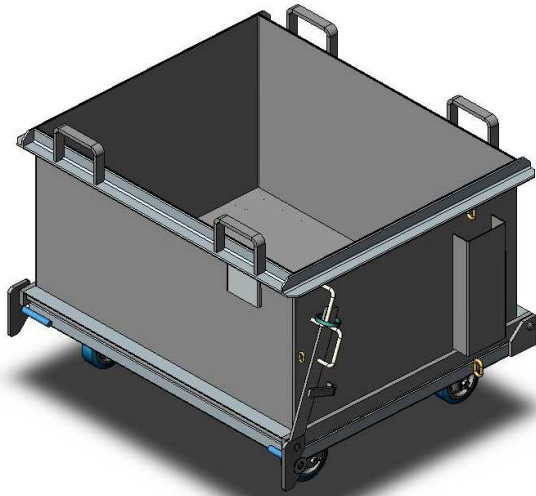

The heavy-duty type DB Drop Bottom Bins have been manufactured from 3mm plate and reinforced to handle all waste products. Transport of the Drop Bottom Bin is by Forklift, Crane or manually manoeuvred on wheels with complete emptying achieved through the release of the drop floor. Powerful shock absorbers remove all impact forces to Forklift or Crane during emptying.

The standard finish is enamel painted.

### SPECIFICATIONS:

- Pocket size 160 x 65mm
- Pocket Centres 684mm
- Safe Working Load 1000kg
- Unit Weight – refer Table
- Volume Capacity – refer Table
- Galvanised Lid Optional

(refer to 'DB Drop Bottom Bin' Product Specifications for all Standard Models)

