

Type DB-M Dirt Bucket

The type DB-M Dirt Bucket is a slip-on attachment allowing quick connection to a Forklift.

This Dirt Bucket is especially useful for removing loose material from floors such as gravel, grain or coal. This bucket has been manufactured with a hardened steel wear edge.

The dumping action is via a simple mechanical lever. The finish is either galvanised or enamel painted.

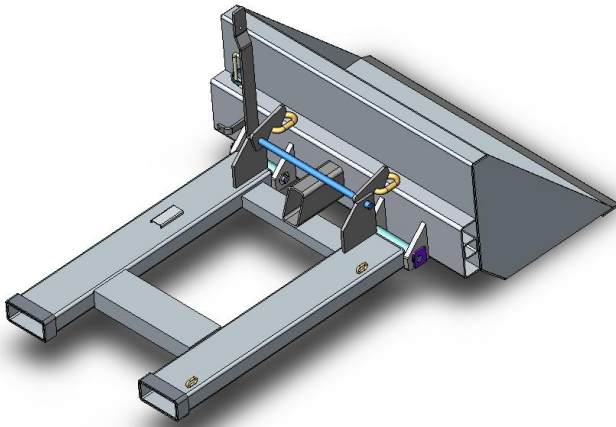

SPECIFICATIONS:

- Pocket size 165 x 65mm
- Pocket Centres 635mm
- Bucket Width 1200mm
- Safe Working Load 500kg
- Unit Weight 198kg
- Volume Capacity 0.22 cu m

