

## Type CMJ-2 Carriage Mounted Jib

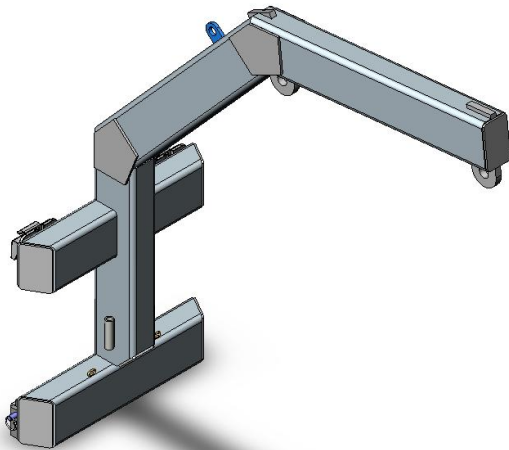

The type CMJ-2 Carriage Mounted Jib has been designed to lift loads up to 1000kg and offers height and manoeuvrability. This unit has been designed with a Class II mounting and features Quick Release lower Carriage Hooks for easy installation. Two hook positions have been incorporated in its design, with the Safe Working Load for each position shown in the diagram below. This unit is supplied with a swivel Hook for lifting.

The Standard finish on this unit is painted enamel, colour black.

### SPECIFICATIONS:

- Safe Working Load (SWL) 1000kg Max.
- Load Centre (for Max SWL) 555mm
- Unit Weight 65kg
- Carriage Mounting Class II
- Horizontal C of G 335mm
- Vertical C of G 690mm

