

Type CDR-500H Crane Drum Rotator

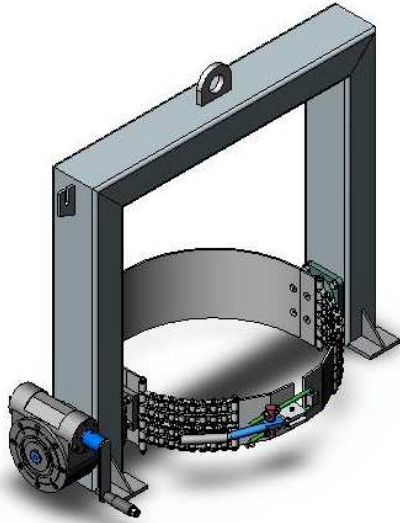

The type CDR-500H Crane Drum Rotator has been specifically designed for use by Crane. The Drum is quickly clamped into the holder via the twin Chain Belly Strap allowing 360° rotation.

This Unit is also available with a Chain driven gearbox for rotation – type CDR-500C.

SPECIFICATIONS:

- Safe Working Load (SWL) 500kg
- Unit Weight 120kg
- 360° Rotation
- Centre of Drum to Lifting Eye 790mm

