

## Type CDR-1000H Crane Drum Rotator

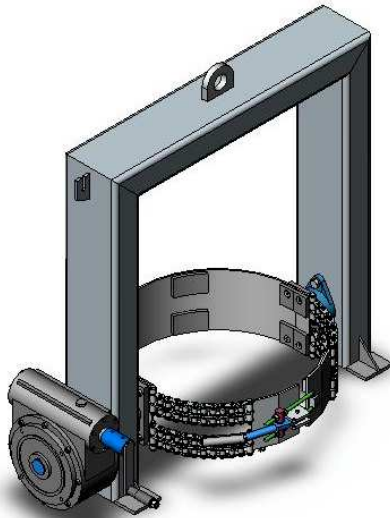

The type CDR-1000H Crane Drum Rotator is a heavy lift capacity Crane Drum Rotator suitable for mining operations, manufacturers and foundries. The Drum is quickly clamped into the holder via the twin Chain Belly Strap allowing 360° rotation.

This Unit is also available with a Chain driven gearbox for rotation – type CDR-1000C.

### SPECIFICATIONS:

- Safe Working Load (SWL) 1000kg
- Unit Weight 220kg
- 360° Rotation
- Rotation Centre to Lifting Eye 940mm

