

Type CDC-1 Crane Drum Clamp

The type CDC-1 Crane Drum Clamp uses a chain belly strap with ratchet tightening to allow clamping of standard 205 litre steel drums. This allows the drum to be transported about the workplace/site safely. The Unit is supplied with Lifting Chains.

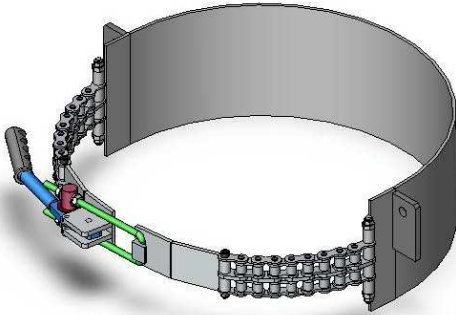

(shown without supplied Lifting Chains)

SPECIFICATIONS:

- Safe Working Load (SWL) 1000kg
- Unit Weight 30kg
- Chain Belly Strap with Over-centre Catch

