

Type CB Universal Carriage

The type CB Universal Carriage is a weld on unit suitable for all machinery and agricultural applications where Fork Tines are to be fitted. Manufactured from high grade steel in accordance with AS2359.11, this Carriage is precision machined to suit either Class 2 or Class 3 Fork Tines. The Safe Working Load (SWL) of this unit varies between 1.5 & 5 Tonne at a Load Centre of 500mm depending on type chosen – refer chart below. These units are supplied unpainted.



(Type CB3-5000 shown above)

SPECIFICATIONS:

- ISO / FEM Carriage Class – refer chart below
- Safe Working Load (SWL) – refer chart below
- Unit Weight – refer chart below
- Supplied Unpainted

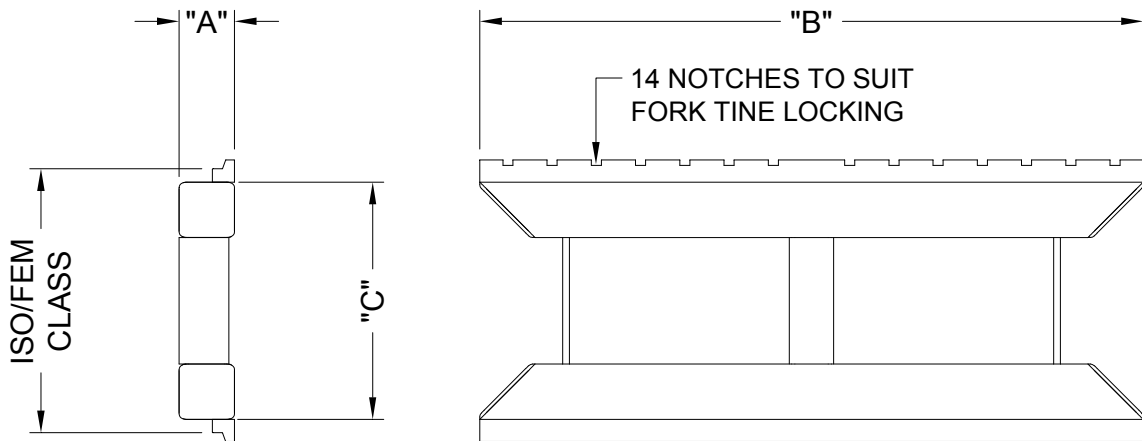

TYPE	ISO / FEM Class	SWL @ 500mm Load Centre	Unit Weight	"A" (mm)	"B" (mm)	"C" (mm)
CB2 - 1500	2	1500 kg	36 kg	60	1200	347
CB2 - 2500	2	2500 kg	44 kg	80	1200	347
CB3 - 5000	3	5000 kg	70 kg	100	1200	428