

## Type BGN-2 Dual Drum Lifter

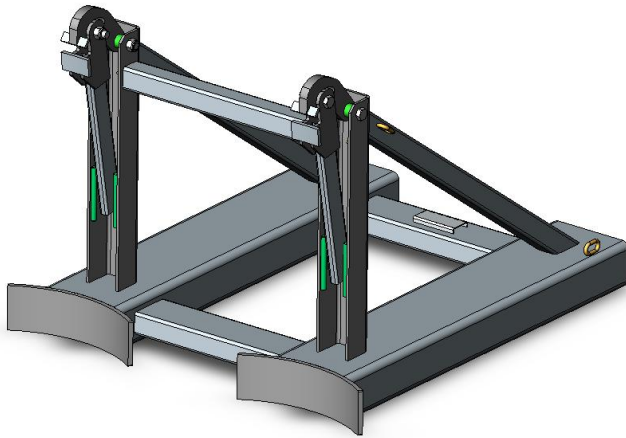

Drum handling made easy. A good field of vision allows the operator to continually observe the drums being handled. The operator does not leave the Driver's seat. The unique beak design provides a high clamping force, even when travelling over uneven ground. The type BGN-2 Dual Drum Lifter has been designed to lift 2 drums side by side or a single drum by either Grab Beak mechanism. With few moving parts, this attachment requires no down time for repairs. This Lifter is suitable for standard 205 litre steel or plastic drums.

A contoured rest acts at a point low enough down the drum to prevent damage to the drum and its labelling.

### SPECIFICATIONS:

- Pocket Size 185 x 60mm
- Pocket Centres 600mm
- Safe Working Load (SWL) 1500kg
- Unit Weight 95kg
- Load Centre 1250mm
- HCG 580mm
- VCG 175mm
- Zinc Plated Finish

