

## Type BGN-1 Single Drum Lifter

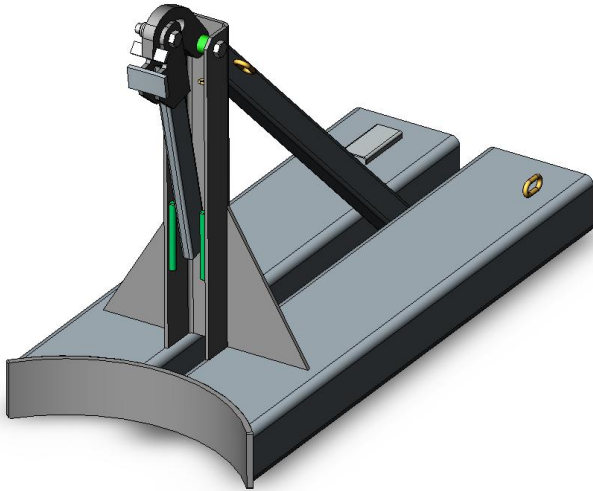

Drum handling made easy. A good field of vision allows the operator to continually observe the drum being handled. The operator does not leave the Driver's seat. The unique beak design provides a high clamping force, even when travelling over uneven ground. With few moving parts this attachment requires no down time for repairs. This Lifter is suitable for standard 205 litre steel or plastic drums.

A contoured rest acts at a point low enough down the drum to prevent damage to the drum and its labelling.

### SPECIFICATIONS:

- Pocket Size 185 x 60mm
- Pocket Centres 250mm
- Safe Working Load (SWL) 1000kg
- Unit Weight 72kg
- Load Centre 1210mm
- HCG 560mm
- VCG 130mm
- Zinc Plated Finish

